

Three-Piece Maintenance Unit

airvision modular



A maintenance unit in block assembly consisting of a filter, a pressure reducer and a fog-lubricator. Additional equipment can be flanged to either side. Many variations are possible by combination with other equipment. Port sizes G 1/8 to G 1.

Technical Data

	I	II	III
Nominal rates of flow***	570NI/min	1200NI/min	1900NI/min
Min. flow rate****	30NI/min	33NI/min	100NI/min
Max. inlet pressure (p₁) plastic bowl / metal bowl		16bar / 25bar	
Outlet pressure range (p₂)		0,5 - 10bar	
Operating temperature		0°C to +50°C*****	
Effective bowl volume			
filter bowl	10 cm ³	25 cm ³	60 cm ³
lubricator bowl	25 cm ³	100 cm ³	120 cm ³
Mounting position		vertical	
Direction of flow		arrow	
Nominal width	DN6	DN15	DN20
Dependence upon supply pres.	<4%	<3%	<3%
Reversing control hysteresis		~ 1 bar	
Weight	800g	1950g	2000g
Material			
Seals		NBR	
Housing	zinc alloy	zinc alloy	aluminium
Filter element		polyethylene	
Plastic bowl		polycarbonate	

*** measured at p₁=8bar, p₂=6bar and Δp=1 bar

**** Oil delivery 10 droplets/min at 6bar / Recommended oil see chapter 8

*****80°C with metal bowl and oiler dome out of metal

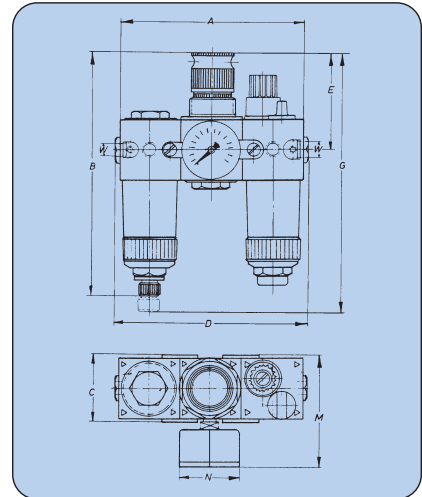

Three-Piece Maintenance Units

Size	G 1/8	G 1/4	G 3/8	G 1/2	G 3/4	G 1
I	450.21*	450.22	-	-	-	-
II	-	-	450.25*	450.26	-	-
III	-	-	-	-	7450.28*	7450.29

special option - how to order:

x450.xxx

- M - metal bowl
- S - bowl protection
- thread (1=G 1/8, 2=G 1/4, 5=G 3/8, 6=G 1/2, 8=G 3/4, 9=G 1)
- 2 - manually-operated drain valve
- 5 - semi-automatic drain valve (0,5-25)
- 6 - external-automatic drain valve A (4-16 bar)
- 7 - external-automatic drain valve B (1-12bar)
- 7 - Size III

Accessories

	I	II	III
Flange connection kit with seal	447-1	447-6	447-20
Bracket mounting (for housing)	444-5	444-14	444-14
Bracket mounting (for top)			
Kit (bracket and nut)	443-36	443-104	443-104

Filter, see page 2

Pressure regulator, see page 4

Lubricators, see page 5

Drain valves, see chapter 7

Dimensions [mm]

Size Port	I G 1/8*, G 1/4	II G 3/8*, G 1/2	III G 3/4*, G 1
A	120	186	210
B**	160	220	274
C	44	68	75
D	126 120	194 186	222 210
E	65	95	100
G**	190	250	320
M	78	100	107

** - semi-automatic drain valve +10 mm
 - external-automatic drain valve B +75 mm
 - external-automatic drain valve A +90 mm

Rates of flow

p₁=p₂+2bar

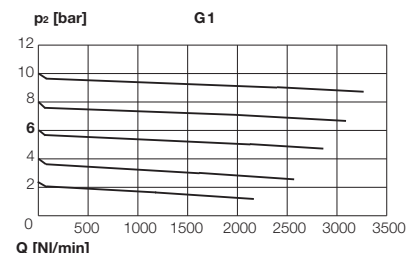
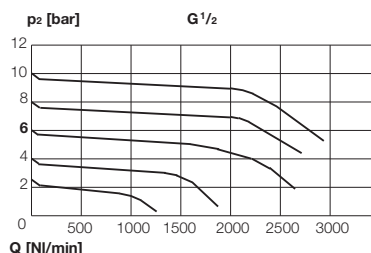
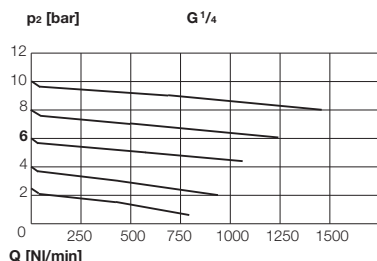

* Inlet and outlet reduced (reducing adapters with O-Rings enclosed)